

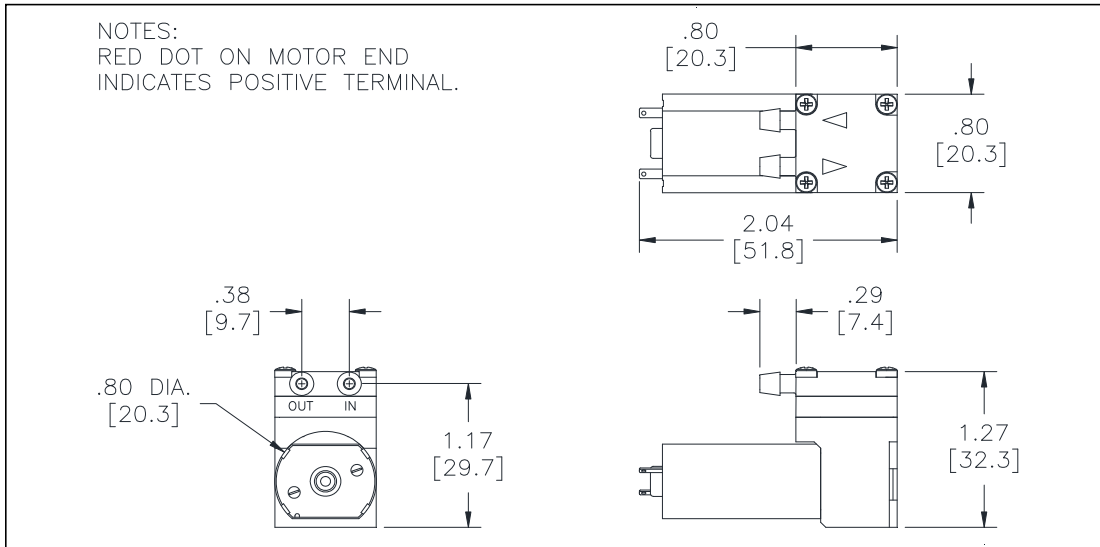

Mooresville, North Carolina 28117  
 T: 704-662-3500 F: 704-662-8744  
 www.parker.com/precisionfluidics

Part No.: **E161-11-060**  
 Model No.: **A.1F17N1.C06VDC**  
 Description: **CTS Diaphragm Pump,  
 Brush Motor**

**Dimensional Layout:**



**Specifications:**

- |                             |                  |                |                       |  |                      |
|-----------------------------|------------------|----------------|-----------------------|--|----------------------|
| <b>1. Wetted Materials:</b> | Pump Head:       | Polysulfone    | <b>3. Electrical:</b> | Motor:                                   | Brush Sleeve Bearing |
|                             | Retainer Washer: | Polysulfone    |                       | Operating Voltage:                       | 6.0 VDC              |
|                             | Retainer Screw:  | 18-8 Stainless | In-rush Current:      | 5 x Operating Current<br>for up to 50 ms |                      |
|                             | Valves:          | EPDM [61]      | Recommended Fusing:   | Slow Blow @ 2 x<br>Operating Current     |                      |
|                             | Diaphragm:       | AEPDM [F80]    |                       |  |                      |
- 
- |                              |                          |                |                  |                    |                |
|------------------------------|--------------------------|----------------|------------------|--------------------|----------------|
| <b>2. Performance: [AIR]</b> | <u>Continuous</u>        | <u>Maximum</u> | <b>4. Other:</b> | Temperature Range: | 5 - 50° C      |
|                              | - Vacuum: in Hg [Bar(g)] | 15.5 [0.52]    |                  | 15.5 [0.52]        | Free Flow RPM: |
|                              |                          |                |                  | Eccentric:         | E350           |
- 
- 5. Operating Limitations:** N/A
- 6. Recommended Filtration:** 40 Micron media w/ a minimum surface area of .24" Sq (152mmSq)

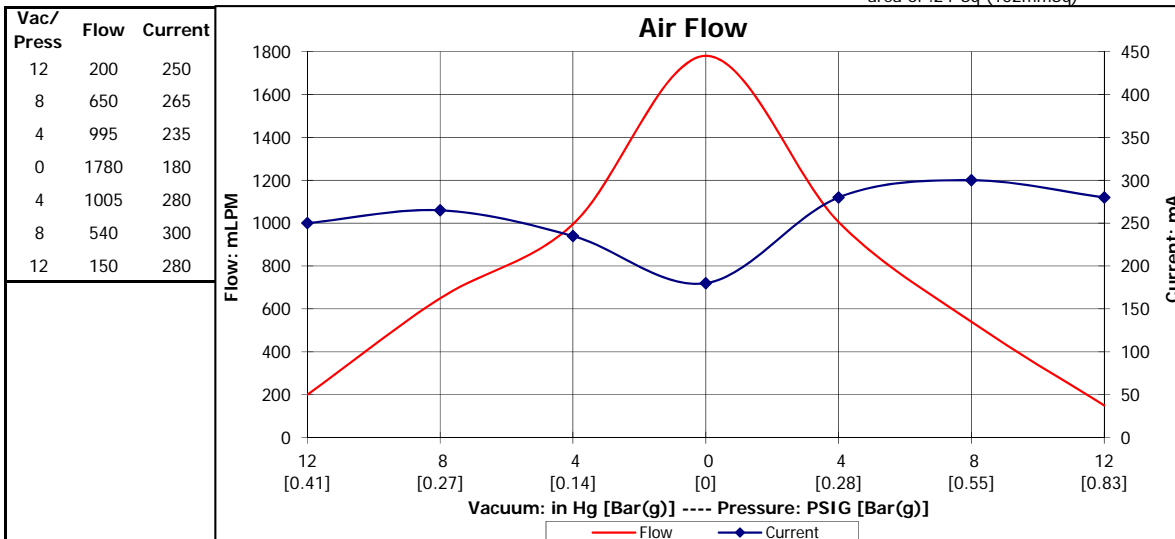

The user, through its own analysis and testing, is solely responsible for making the final selection of the system and components and assuring that all performance, endurance, maintenance, safety and warning requirements of the application are met. The user must analyze all aspects of the application, follow applicable industry standards, and follow the information concerning the product in the current product catalog and in any other materials provided from Parker or its subsidiaries or authorized distributors.

The above graph denotes nominal performance at 800' above sea level, 24°C, and at the specified voltage.

PR